

# Componenti



Testata inferiore con molla da 700  
Cod. MIA 22



Coppia cuffie Cod. K 60



Testata superiore con boccola  
Cod. MIA 19



Scivolo Superiore Cod. MIA 03



Scivolo inferiore Cod. MIA 08



Attacco guida testata  
Cod. MIA 18



Passa Filo Cod. MIA 05



Tirante filo con molla  
Cod. MIA 20

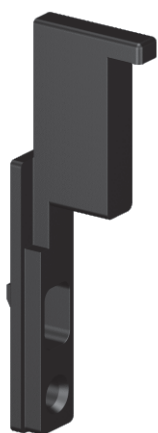

Ferma guida  
Cod. MIA 21

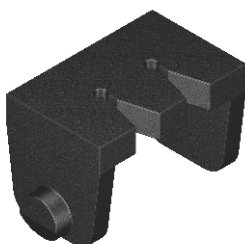

Aggancio filo al carrello  
Cod.

# Componenti



Coppia giunzione guida blocca  
anta  
per 2 ante Cod. MIA 23



Set catenaccio superiore  
Cod. MIA 11SL



Set catenaccio inferiore  
Cod. MIA 13



Coppia agganci per cassonetto  
Cod. K 68



Accoppiatore cassonetto  
Cod. MIA 25



Cuffia giunzione compensatore  
Cod. MIA 24



Carrello cm 140

Cod. RO 01S

Set completo per 1 anta  
Cod. SMIA140



Maglia con spazzolino  
Cod.



Filo  
Cod. FL01



Profilo magnete per 1 anta  
Cod. PM 134



Profilo magnete per 2 ante  
Cod. PM 72

Viteria



Viti 2,9 x 16 pz 8 per testate cassonetto - per scivoli sup. e inf.

Viti 2,9 x 9,5 pz 4 per scivoli inferiore



Grani m5 x 6 pz 5 per passa filo- snodo-tiranti ferma guida

Grani m 5 x 10 pz 6 per agganci cassonetto - pz 4 per giunzione guida 2 ante

# Istruzioni

Taglio profili:

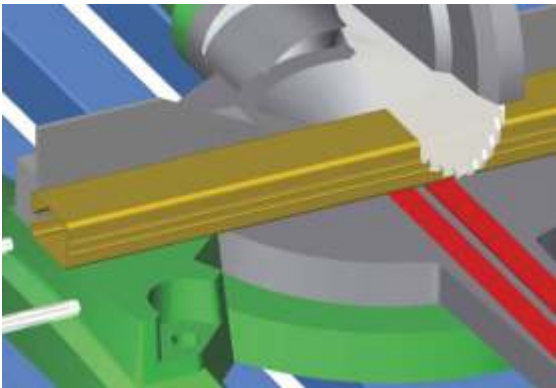

Taglio cassonetto:  
Misura zanzariera - mm 24

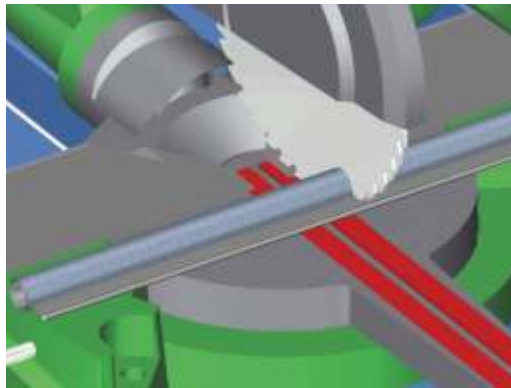

Taglio tubo:  
Misura zanzariera - mm 29

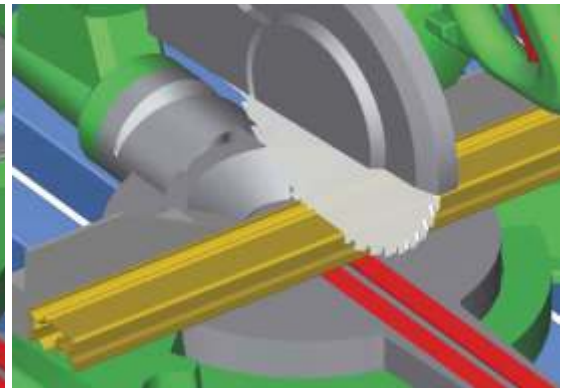

Taglio maniglia:  
Misura zanzariera - mm 100

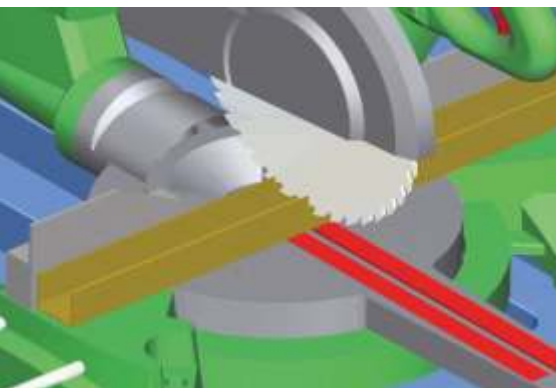

Taglio compensatore:  
Misura zanzariera - mm 4

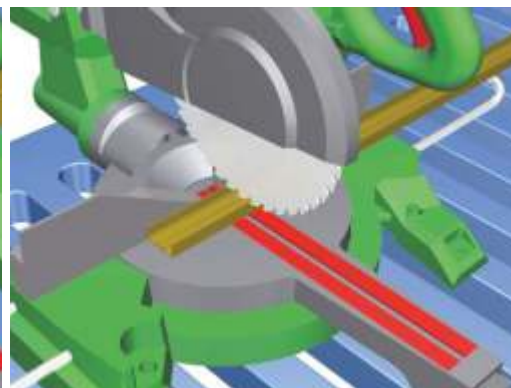

Taglio riscontro:  
Misura zanzariera - mm 35

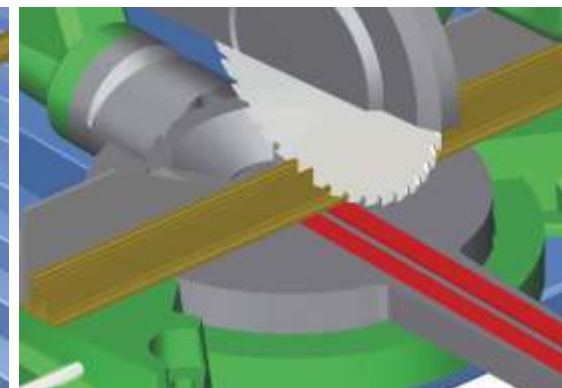

Taglio guida superiore 1 anta:  
Misura zanzariera - mm 155  
Taglio guida superiore 2 ante  
e accoppiata:  
Misura zanzariera - mm 294  
diviso 2

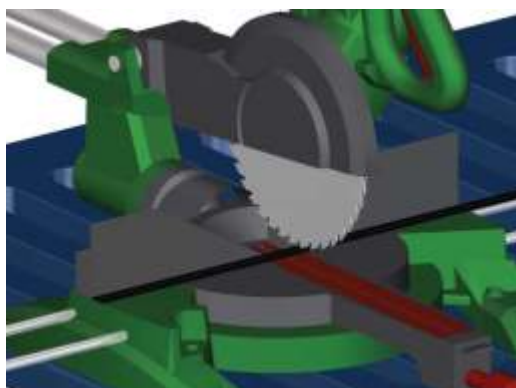

Taglio guida inferiore 1 anta:  
Misura zanzariera - mm 12

Taglio guida inferiore 2 ante:  
Misura zanzariera - mm 126 diviso 2 .  
Esempio mis. zanzariera 1500 meno 126 = 1374 diviso 2 = 687

Taglio guida inferiore accoppiata:  
Misura zanzariera - mm 75 diviso 2.  
Esempio mis. zanzariera 1500 meno 75 = 1425 diviso 2 = 712,5

# Assemblaggio:

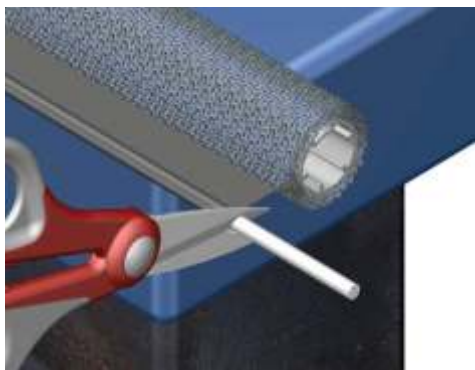

Tagliare il tondino meno **mm 38**  
poi spingerlo verso l'interno  
della fettuccia

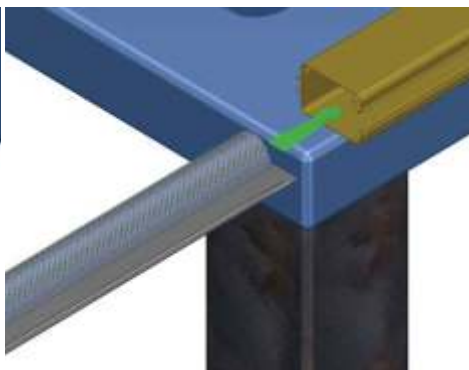

Inserire il tubo rete  
nel cassonetto

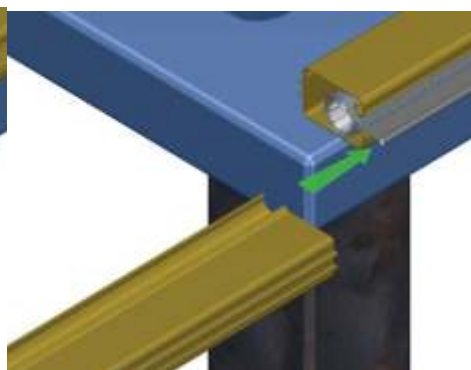

Inserire la barra maniglia

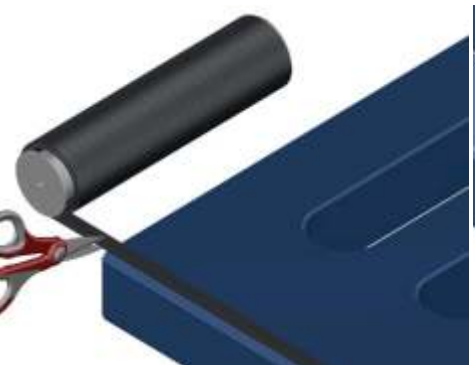

Tagliare il profilo magnetico alla misura della barra maniglia + **mm43**

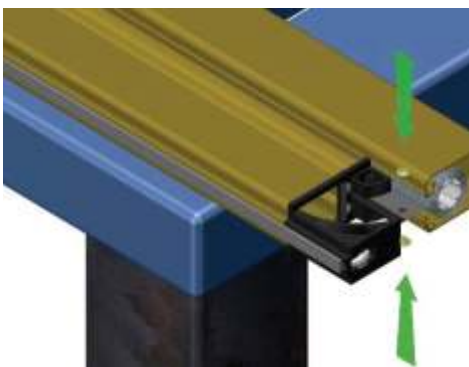
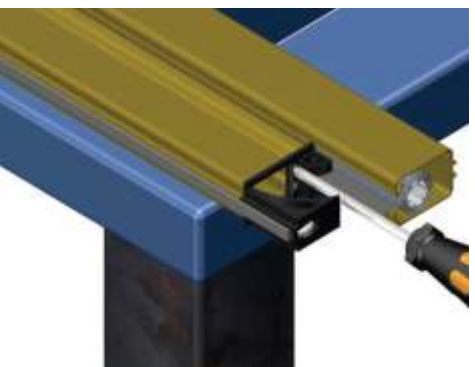
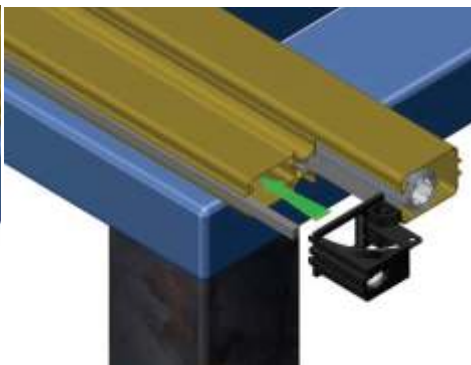
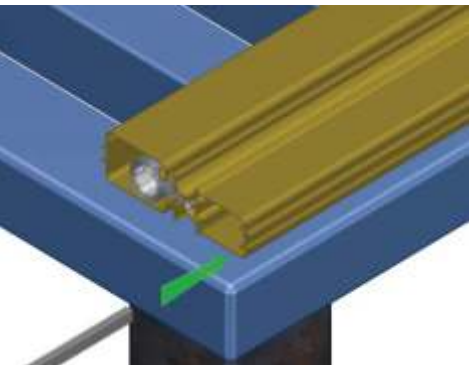

Inserire lo scivolo inferiore alla barra maniglia e fissarlo con le viti ts 2.9 x 19, poi rivettare  
la fettuccia allo scivolo.

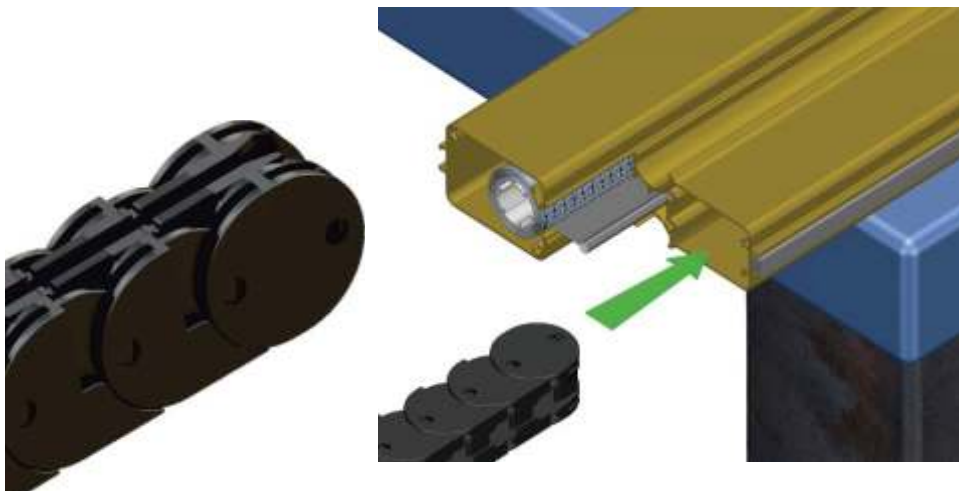

Inserire il carrello nella barra maniglia dalla parte come da foto evidenziata.



Tagliare n. 1 pezzo di filo calcolando la misura dell'altezza della zanzariera + larghezza + cm 15 meno la misura del carrello

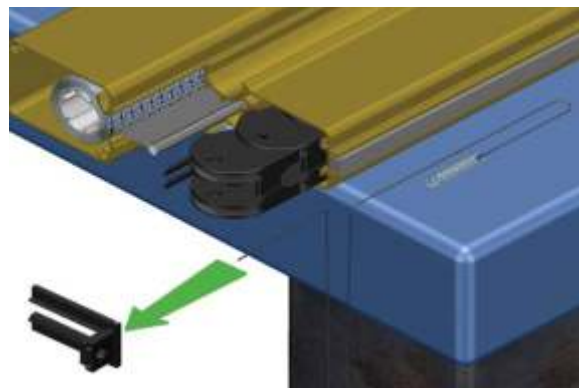
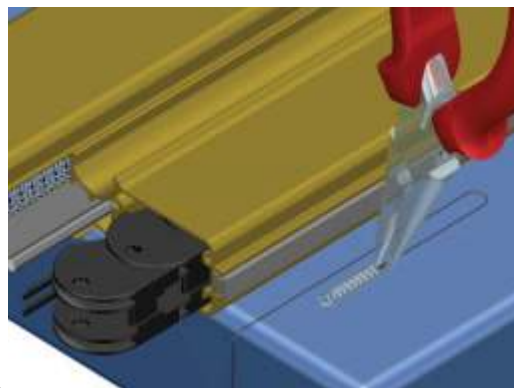

Legare il filo alla molla poi passarlo attraverso un foro del passafilo.

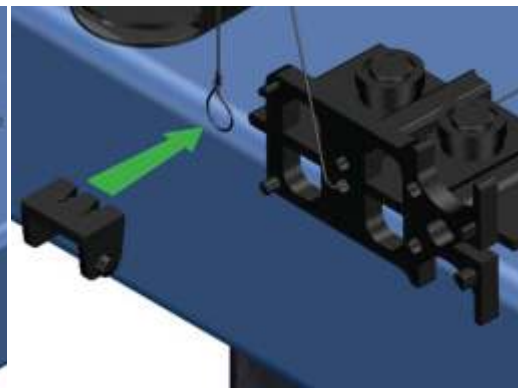
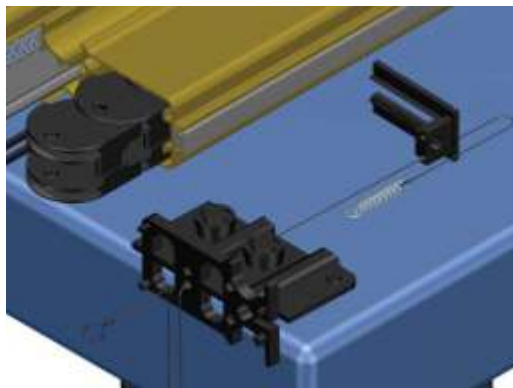
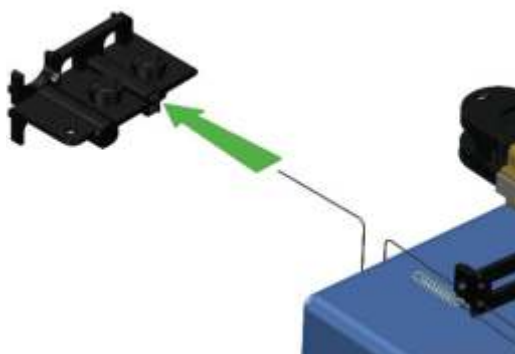

Passare il filo da un foro dello scivolo superiore, fare un nodo a scorrimento al filo e agganciarlo all'aggancio carrello

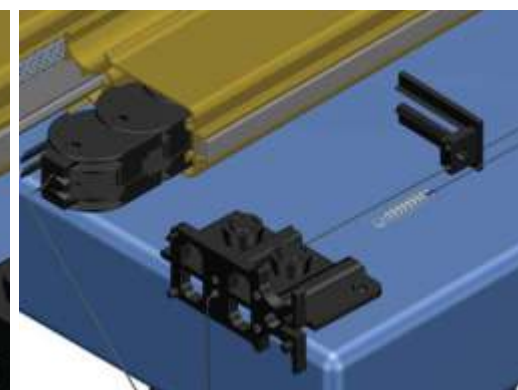
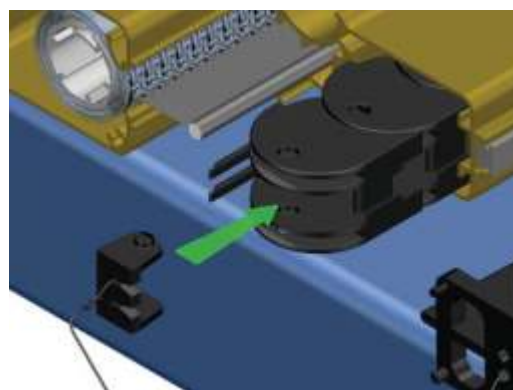
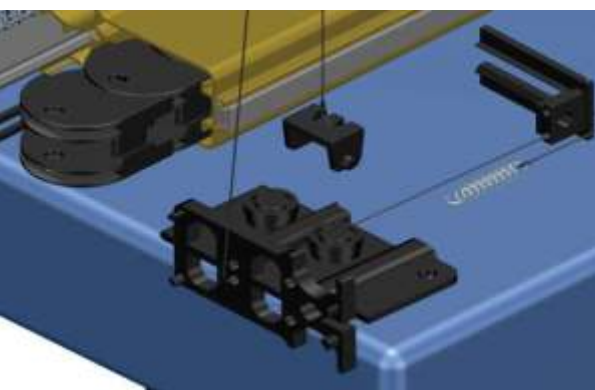

Agganciare il pezzo con il filo al carrello

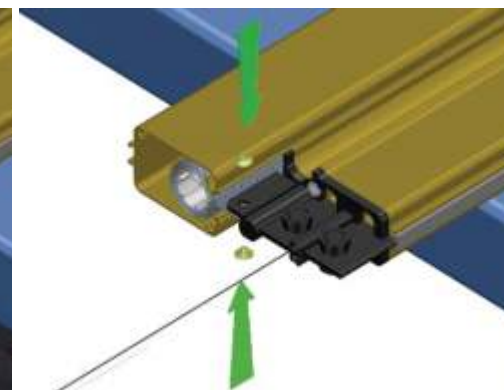
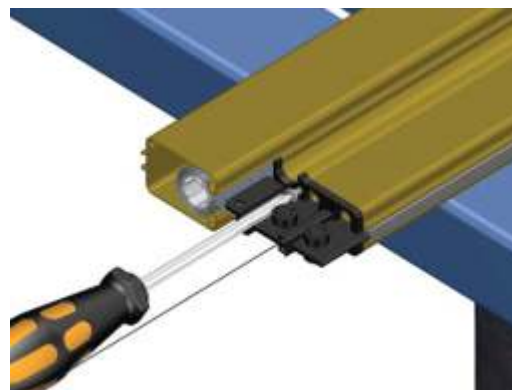
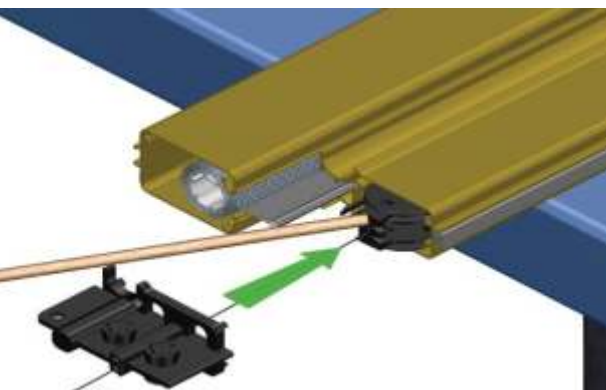

Spingere il carrello all'interno della barra maniglia fino all'uscita dallo scivolo inferiore posizionare lo scivolo superiore alla barra maniglia e fissarlo tramite le viti ts 2,9x19





Distanziare la barra maniglia circa 10 cm dal cassonetto, poi inserire la boccola e la testata fissandola con le viti ts 2,9x19, prima di inserire la molla avvolgere il tubo rete fino al congiungimento al cassonetto.

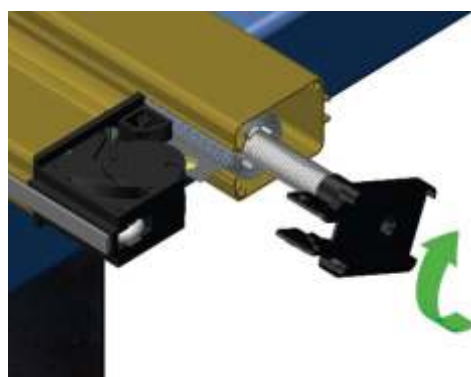

Caricare la molla a 14 Giri



Fissare la testata con le viti ts 2,9x19

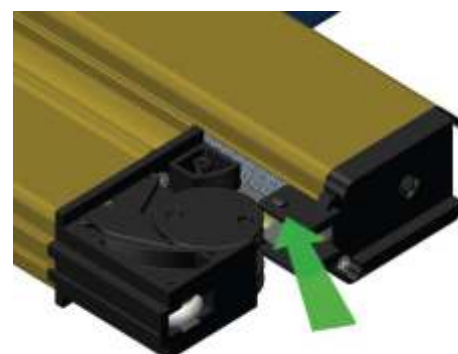

Agganciare il carrello alla testata

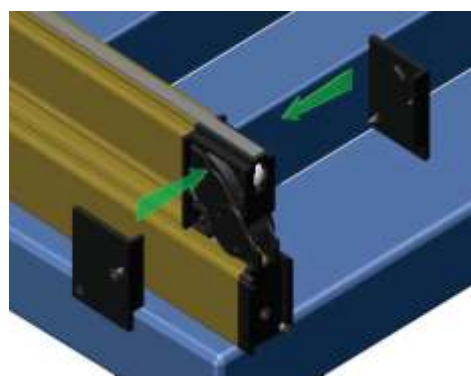

Posizionare i tappi dello scivolo inferiore nelle proprie sedi e fissarli tramite le viti ts 2,9x9,5

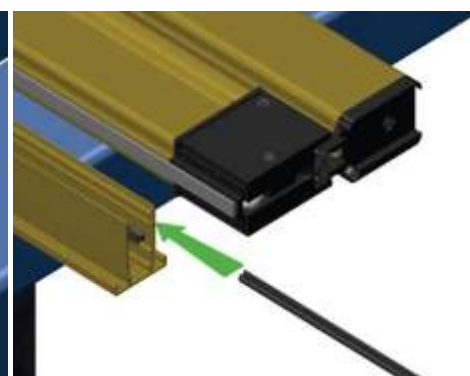
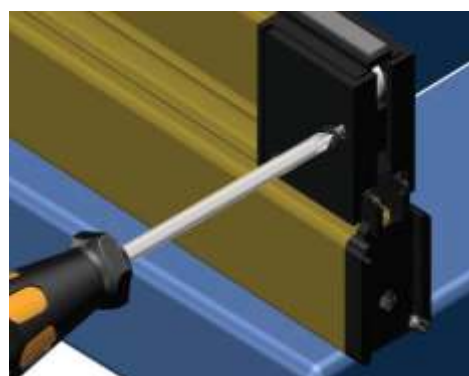

Inserire lo spazzolino 5x5 nelle sedi della guida superiore

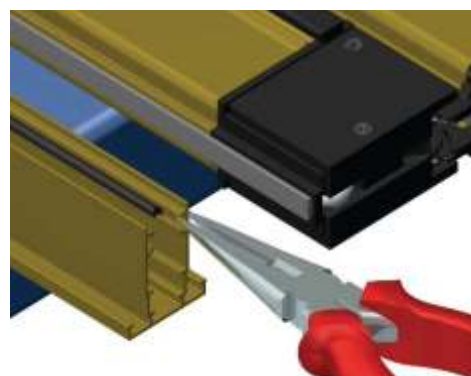

Pinzare l'estremità delle sedi del spazzolino parte attacco guida

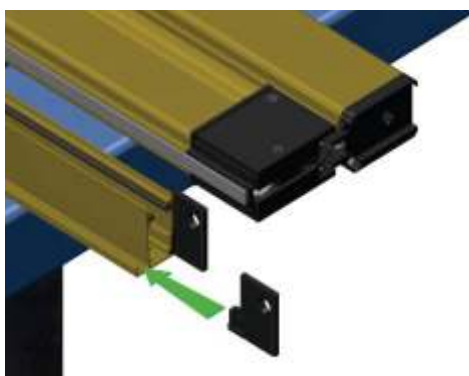

Inserire alla guida gli attacchi alla testata e fissarli tramite i grani M5x6

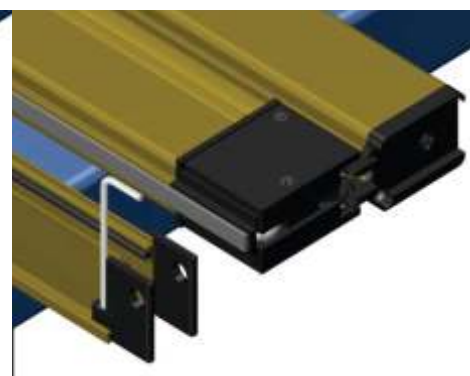

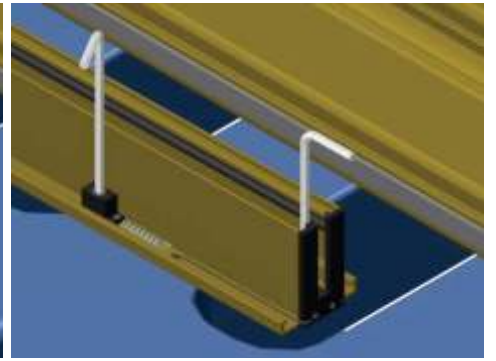
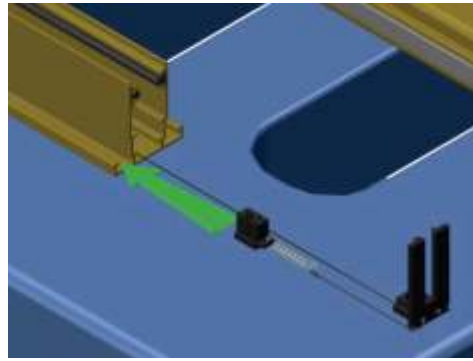
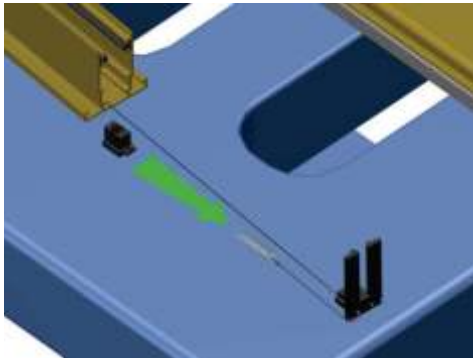

Agganciare la molla al tirante filo e inserirlo nella sede della guida poi inserire il passa fili, bloccare il passa fili con il grano m5x6

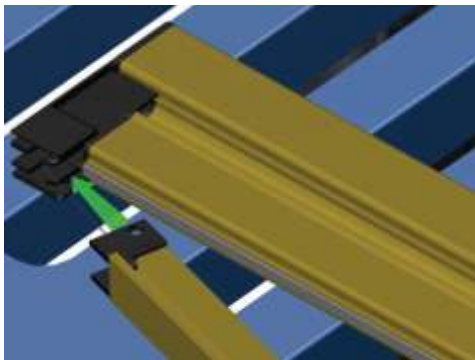

agganciare la guida tramite alla testata superiore

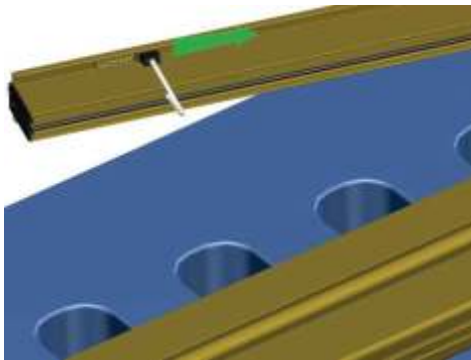

Regolare il tirante fino alla tensione del filo senza allungare la molla

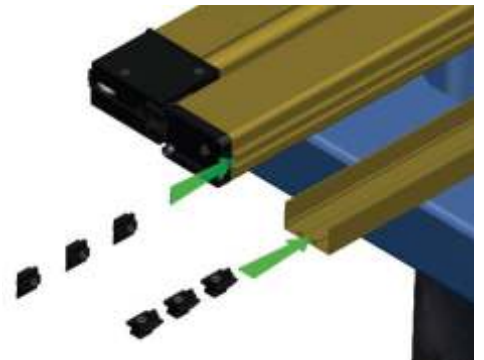

Inserire n. 3 agganci nella sede del cassonetto con la punta rivolto il basso, mentre nel profilo di battuta verso l'alto

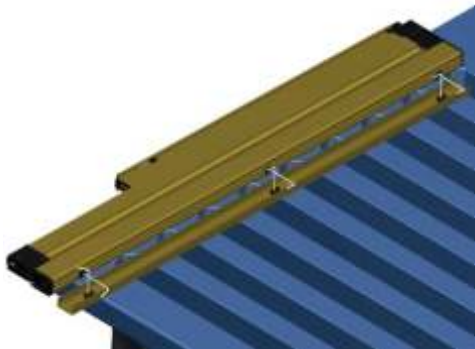

Fissare prima gli agganci presenti nel cassonetto con i grani m5x10 di conseguenza regolare gli agganci nel profilo di battuta in modo da accoppiarsi in fase di installazione e fissarli

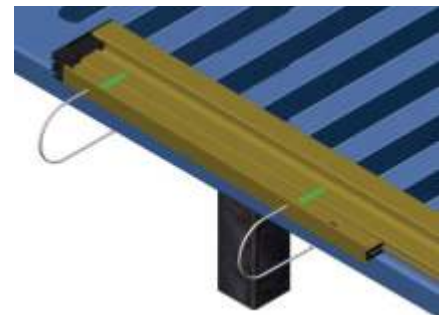
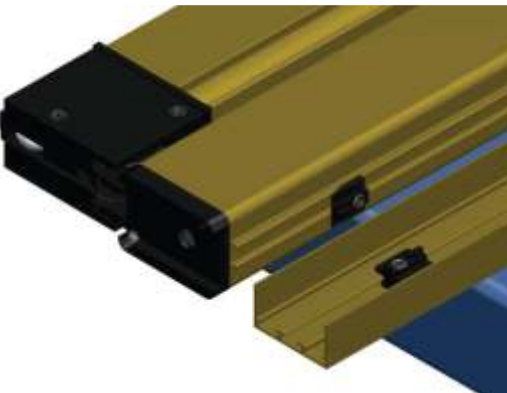

Fissare la guida con delle fascette

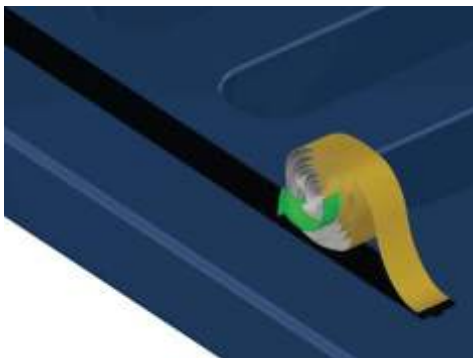

Applicare il biadedivo alla guida inferiore



Tagliare il profilo magnetico alla misura del profilo di riscontro e inserirlo nella apposita sede.

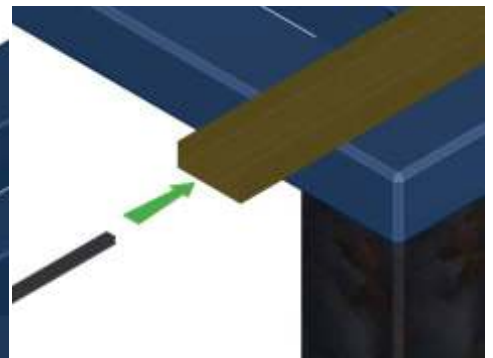

## Assemblaggio due ante:

Eeguire gli stessi passaggi precedenti modificando i seguenti:

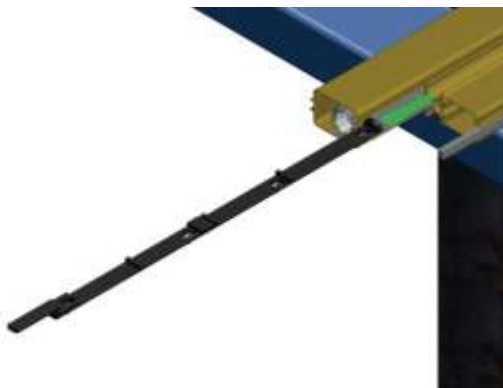
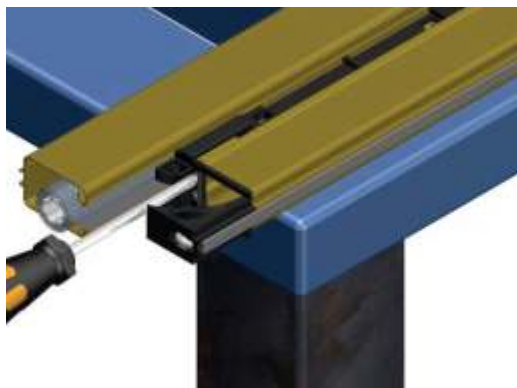

Prima di fissare lo scivolo inferiore inserire il catenacciolo inferiore

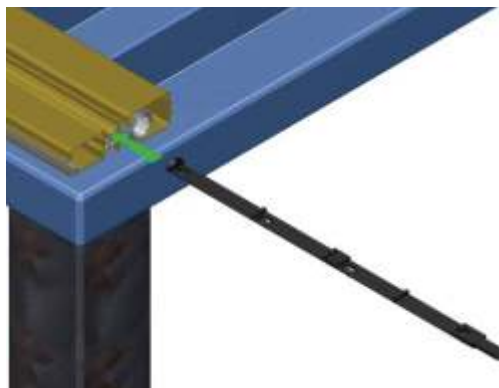
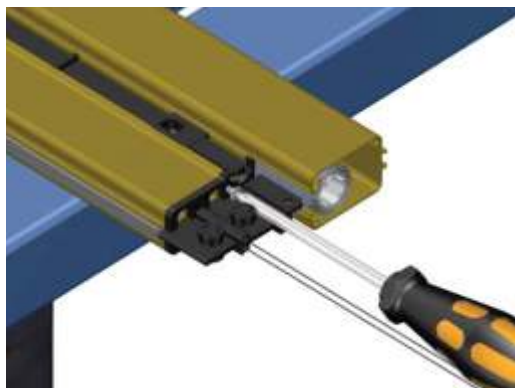

Prima di fissare lo scivolo superiore inserire il catenacciolo superiore

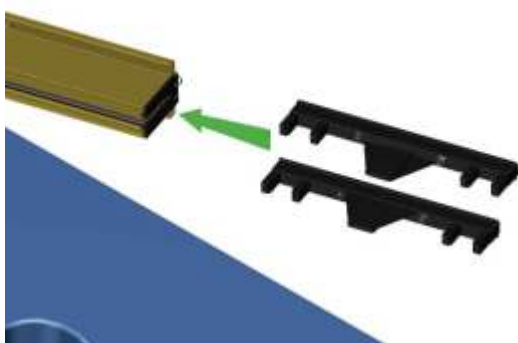

Inserire in una anta nella guida il fermo per il catenacciolo , fermarli con i grani M5 x10

# INSTALLAZIONE

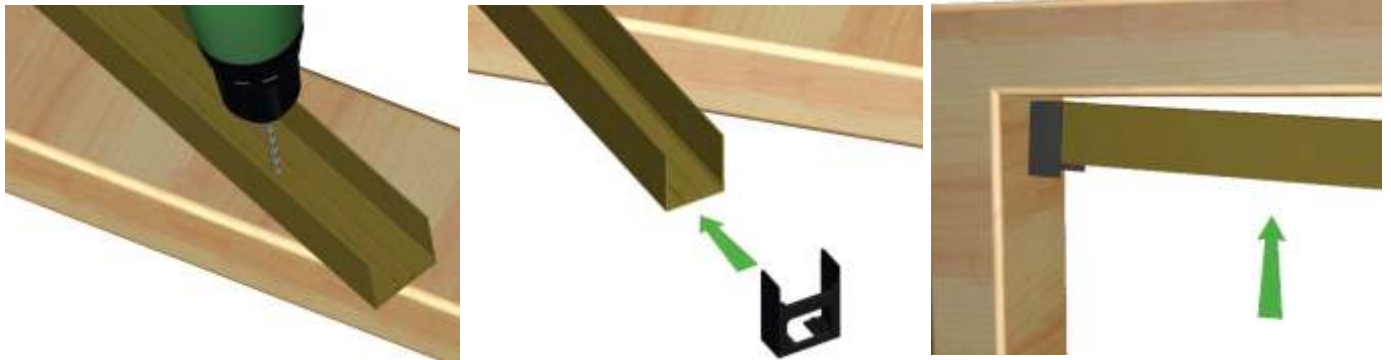

Praticare dei fori per il fissaggio al compensatore, inserire le cuffie di compensazioni e fissarlo al vano superiore

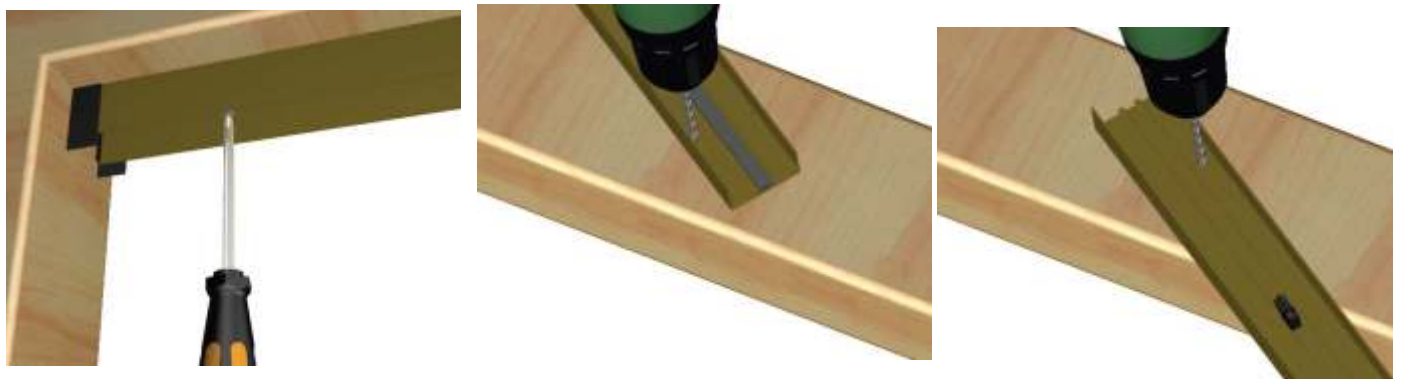

Praticare dei fori per il fissaggio ai profili di riscontro

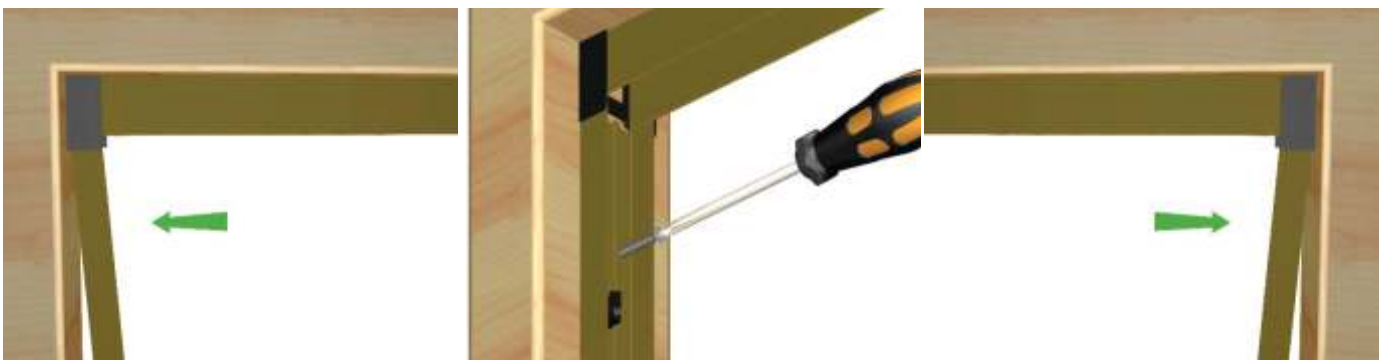

Inserire in diagonale i profili di riscontro tra le alette delle cuffie facendo attenzione nella fase di fissaggio che restano in linea con il profilo compensatore

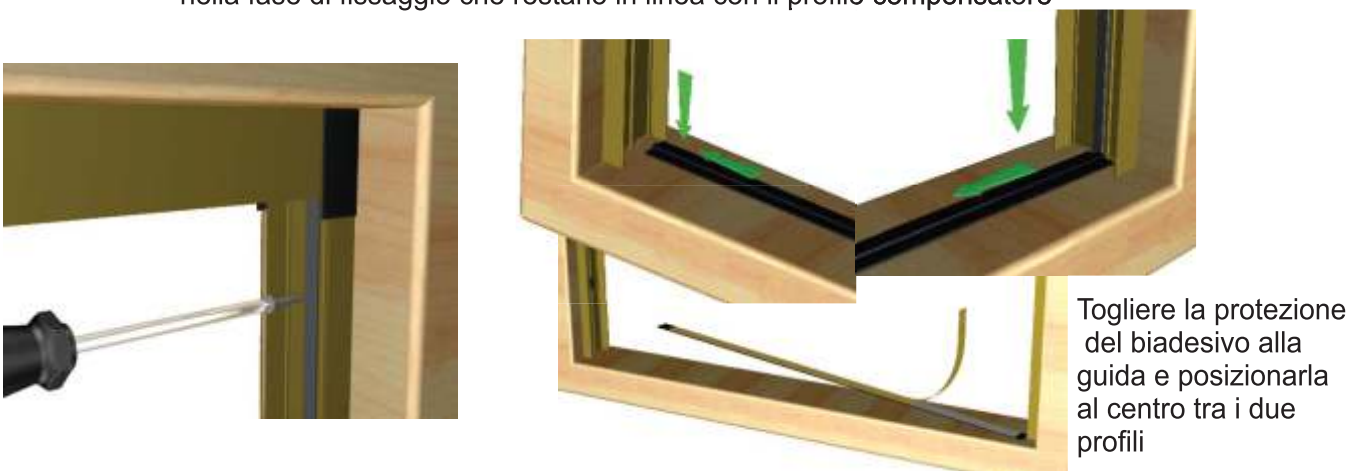

Togliere la protezione del biadesivo alla guida e posizionarla al centro tra i due profili

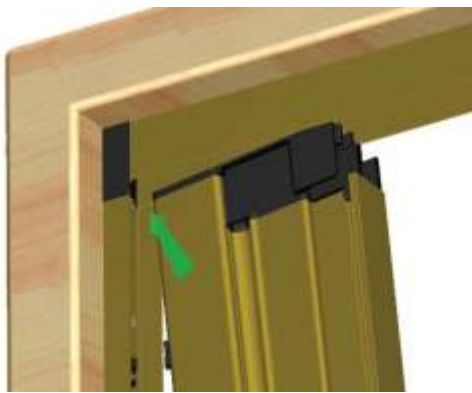

Inserire il pacchetto zanzariera inclinato nel compensatore e portalo in posizione di aggancio

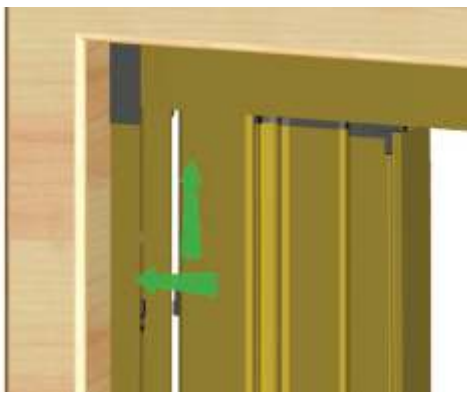

Togliere le fascette ferma guide, alzare il pacchetto e spingerlo verso il riscontro poi verso il basso in modo da far accoppiare gli agganci

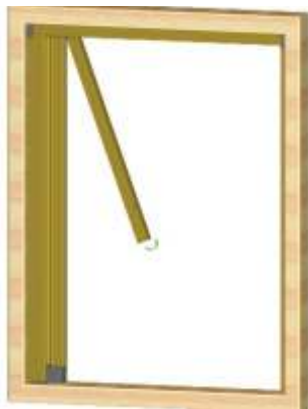
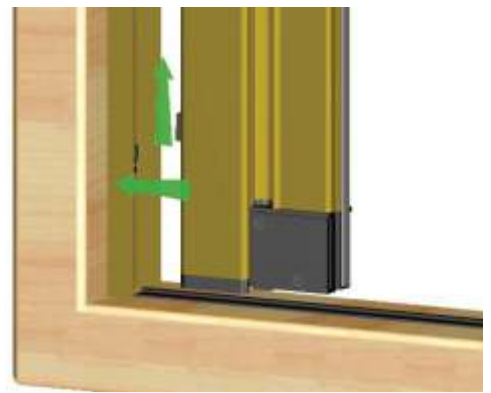

Ruotare la guida portare in avanti la barra maniglia in modo che la guida resta in posizione

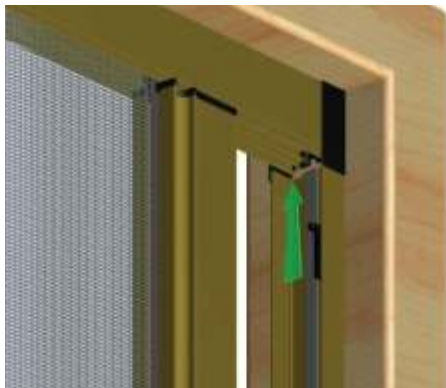
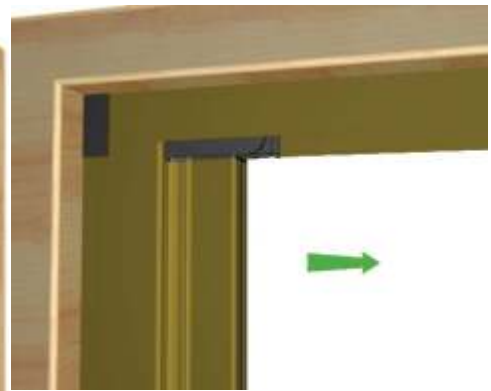

Bloccare la guida tramite il ferma guida con il grano m 5 x 6

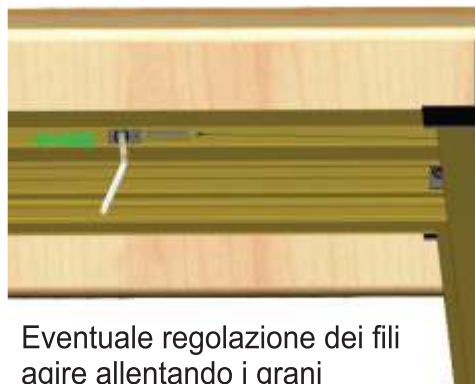

Eventuale regolazione dei fili agire allentando i grani e spostando il tirante.

## INSTALLAZIONE 2 ANTE

Procede alla installazione istruzioni per 1 anta

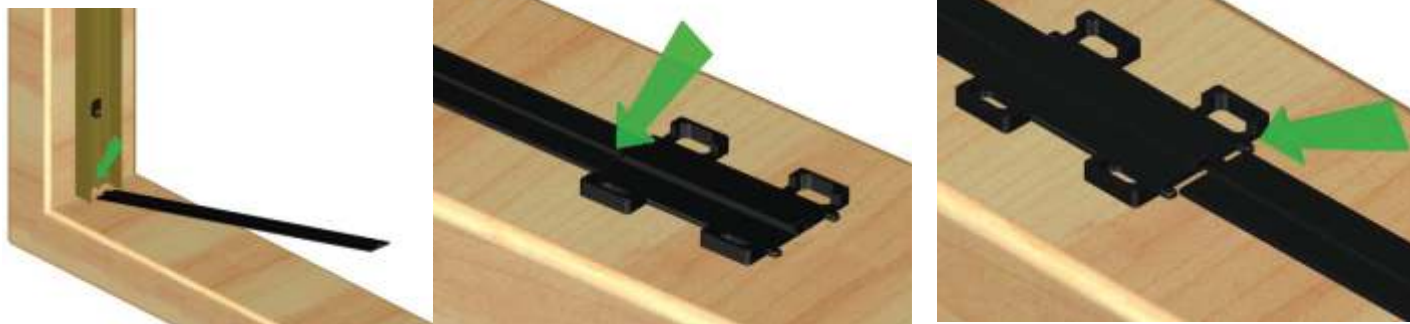

Togliere la protezione del biadesivo della guida e piattina blocca anta e posizionarli nel vano inferiore

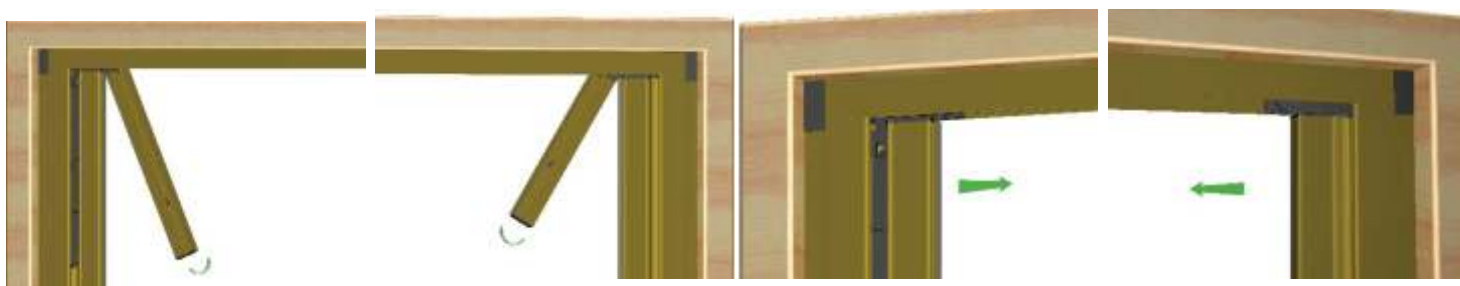

Posizionare le guide verso il compensatore e portare in avanti le barre maniglie per allineare le guide



Spostare le giunzioni ferma anta al centro delle due guide e fissarle tramite i grani m5x10

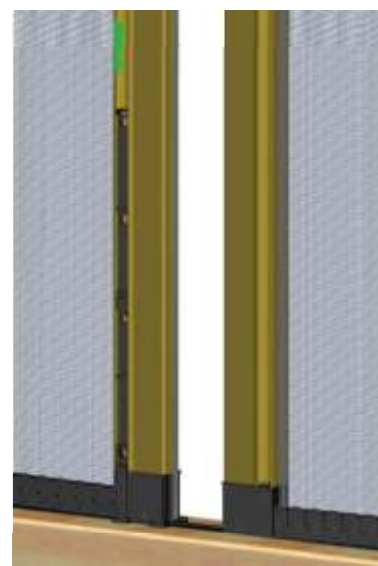
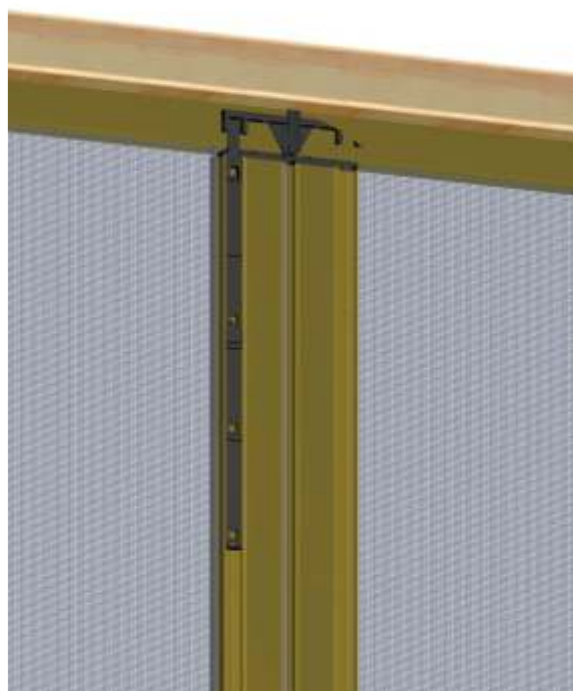

Eventuale regolazione dei fili agire allentando i grani e spostando i tiranti.

## INSTALLAZIONE ACCOPPIATA:

Procedere alla installazione del telaio come 1 anta

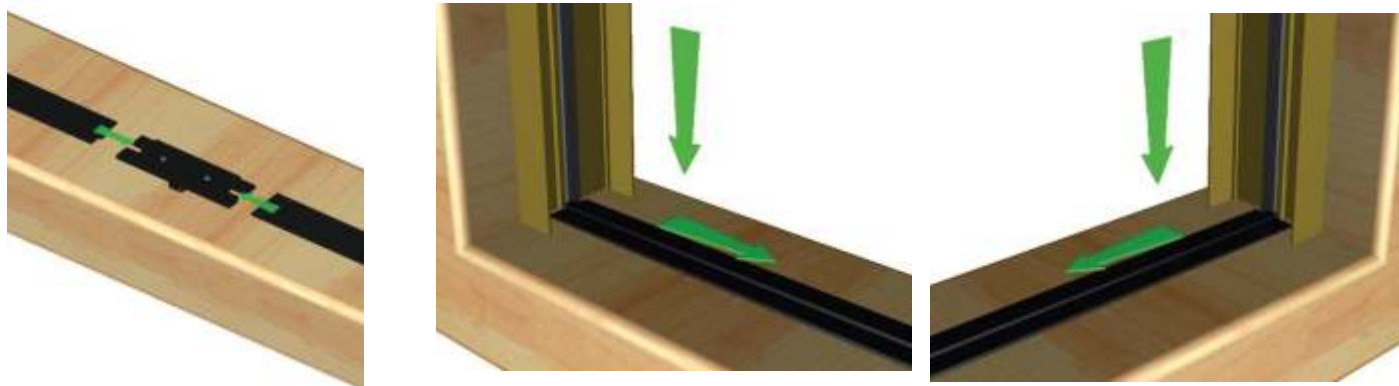

Inserire l'accoppiatore alle guide e poi fissare al vano il tutto



Posizionare il cassonetto a contatto con l'accoppiatore, procedere anche per l'altro cassonetto

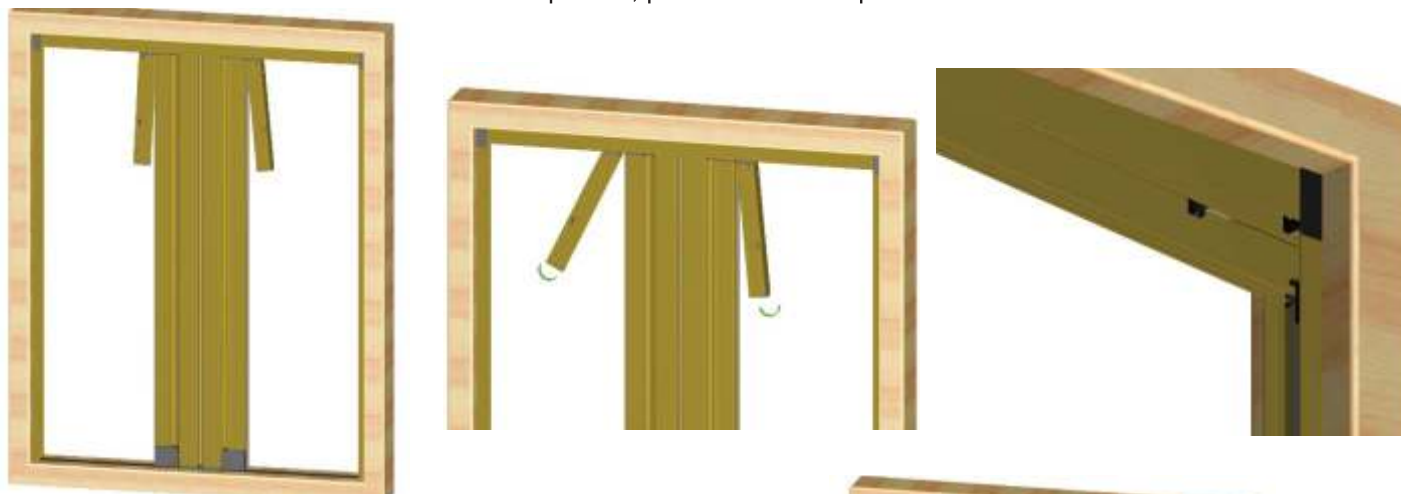

Alzare le guide e portarle a contatto con il compensatore



Aprire la zanzariera in modo che la guida si allinea, posizionare il blocca guida e fissarlo

